

## 1" O.D. Heavy Duty Stainless Steel Grab Bar with Concealed Mounting

### Product Materials

**FLANGES:** 3/8" dia. 13 gauge stainless steel.

**ESCUTCHEONS:** 22 gauge stainless steel. One-piece drawn construction with exposed surfaces in architectural satin finish. Snap over flanges to conceal mounting screws.

**TUBING:** 1" O.D. 18 gauge stainless steel, seamless construction with exposed surfaces in architectural satin finish. Bent ends of tubing pass thru the flanges and are welded for maximum strength. Intermediate supports are contour cut and joined by welding to form an integral part of the grab bar. All welds ground and polished to blend. Mandrel bending process maintains uniform bar diameter. Return provides 1 1/2" standard safety clearance between wall and bar.

### Strength

When properly mounted, all Bradley heavy duty grab bar systems meet or exceed the requirements of ANSI Standard A117.1, the ADA and ABA Accessibility Guidelines for Buildings and Facilities (ADAAG), and the Uniform Federal Accessibility Standard (UFAS). Select dimensions of configurations are 3rd party tested to support up to 900 pounds. See configurations below. All other 852 grab bars outside of these parameters are rated to support up to 250 pounds. Wall must be reinforced in the area of the grab bar in order to support the load it is intended to support.

### Guide Specification

Grab bar shall be satin finish stainless steel with concealed mounting flanges in sizes and configurations as indicated. Install with Bradley Mounting Kits as indicated.

### Installation

For instructions on installation, warnings and maintenance, please visit [www.bradleycorp.com](http://www.bradleycorp.com).

### Optional Features

Features	Suffix
Safety-Grip Finish	-2

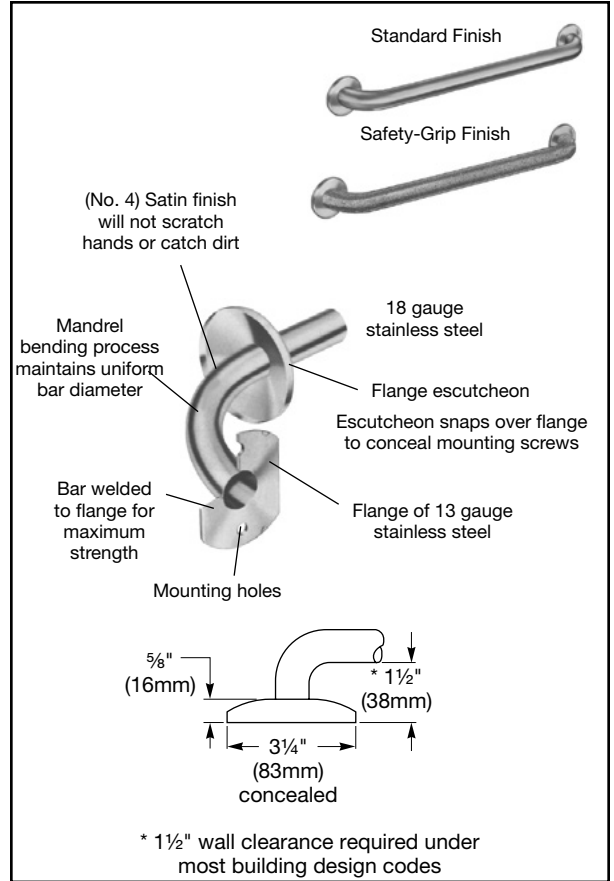

### BradEX® Models

Configuration Number	Shipping Data	
	Cu. Ft.	Wt. Lb.
001-18"	0.14	2
001-24"	0.14	2

### Configuration Information

OD		1"
Rating (LB)		900
Configuration Number	Grab Bar Length	852 Series
001-18	18"	X
001-24	24"	X

**BradEX®** Item - Standard Finish

Orders composed of products indicated as **BradEX®** will be available to ship in three days after receipt of order at the factory. There is no pricing penalty for this service from Bradley.

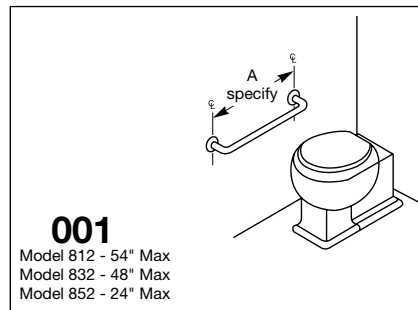

**WARNING** Only models/configurations listed in the configuration information table have been rated for use up to 900 pounds. Please see **Grab Bar Configurations on [bradleycorp.com](http://bradleycorp.com)** for all other available configurations.